



**Technical Service
BULLETIN**

January 17, 2005

Title:

**BLOWER MOTOR ONLY WORKS ON
HIGH SPEED**

Models:

'00 – '03 ECHO

**HEATING & AIR CONDITIONING
AC001-05**

Introduction Some 2000 to 2003 model year ECHO vehicle customers may experience a blower fan that only works on high speed. A production change was implemented to the air duct to prevent this condition. This TSB provides a field-fix repair to improve this condition. Follow the repair procedures described below.

- Applicable Vehicles**
- **2000 – 2003** model year **ECHO** vehicles produced **BEFORE** the Production Change Effective VINs shown below.

**Production
Change
Information**

PLANT		PRODUCTION CHANGE EFFECTIVE VIN
Takaoka	Line 1	JTD*T1#3#30290895
	Line 2	JTD*T1#3#35048679

**Parts
Information**

PREVIOUS PART NUMBER	CURRENT PART NUMBER	PART NAME	QTY
87391-52020	87391-52021	Cover, Blower Motor	1
87138-52010	Same	Resistor, Blower	1
87103-52040	Same	Motor Assembly, w/Fan (USA Cold Spec)	1
87103-52060	Same	Motor Assembly, w/Fan (USA except Cold Spec)	1
N/A	88568-52010-83	Air Filter, Cabin	1
N/A	87529-0E010	Label A/C Filter	1

**Warranty
Information**

OP CODE	DESCRIPTION	TIME	OFF	T1	T2
AC4010	HVAC Improvement	1.0	87391-52020	72	17

Applicable Warranty*:

This repair is covered under the Toyota Comprehensive Warranty. This warranty is in effect for 36 months or 36,000 miles, whichever occurs first, from the vehicle's in-service date.

* Warranty application is limited to correction of a problem based upon a customer's specific complaint.



**Repair Procedure:
Inspection**

Inspect HTR Fuse, Blower Resistor and Blower Motor

1. Inspect HTR Fuse.

- A. Remove the HTR fuse from the instrument panel Junction Block.
- B. Visually inspect heater fuse. If the fuse is open, replace the HTR fuse.

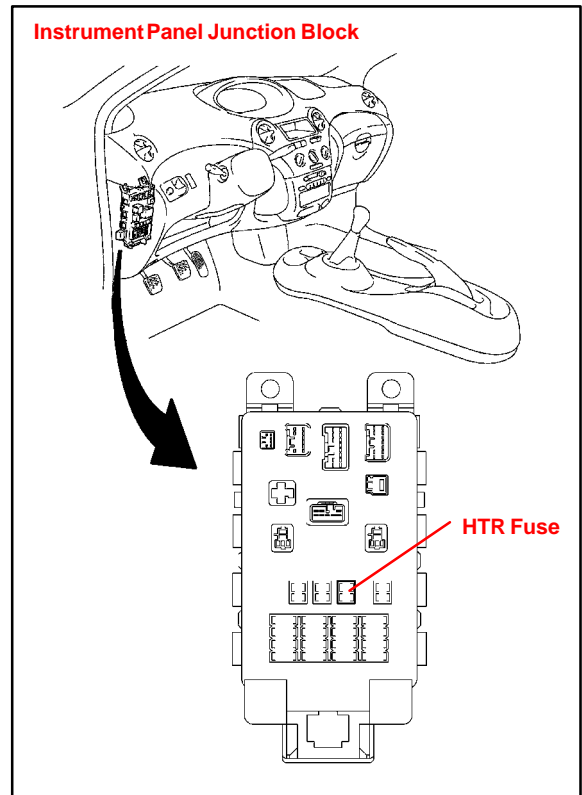

2. Inspect Blower Resistor Resistance.

Tester Connection	Condition	Specified Condition
1 – 3	Constant	Approx. 0.4 Ω
1 – 2	Constant	Approx. 1.5 Ω
1 – 4	Constant	Approx. 2.8 Ω

If resistance is not as specified, replace the blower resistor.

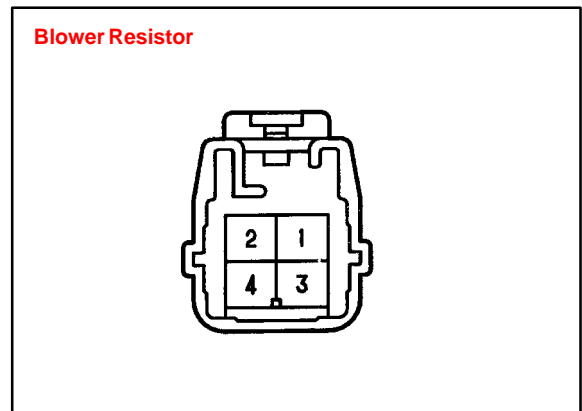

Repair Procedure: Inspection
(Continued)

3. Inspect Blower Motor Operation.

Connect the positive (+) lead from the battery to terminal 1 and the negative (-) lead to terminal 2. Then check that the motor operates smoothly. If operation is not as specified, replace the blower motor.

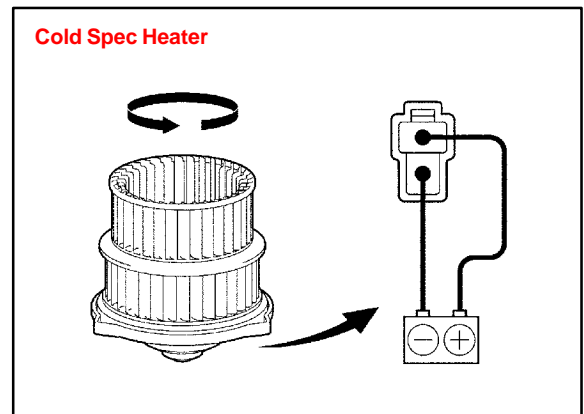
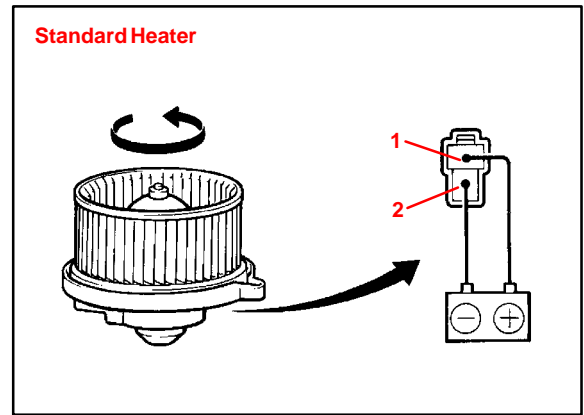

Repair Procedure: Replacement

Replace Blower Resistor and Blower Motor

1. Remove Glove Compartment Door.
2. Remove Engine Engine Control Module or ECM (SAE term: Powertrain Control Module/PCM).
 - A. Disconnect the wire harness clamps.
 - B. Disconnect the connectors.
 - C. Remove the 2 bolts and engine ECM (PCM).
3. Cold Spec Heater Models Only: Remove Air Duct (Motor Cover).
 - A. Disconnect the control link.
 - B. Disconnect the connectors.
 - C. Disconnect the connector clamps.
 - D. Disconnect the wire harness clamps.
 - E. Remove the screw.
 - F. Release the claw and remove the air duct.

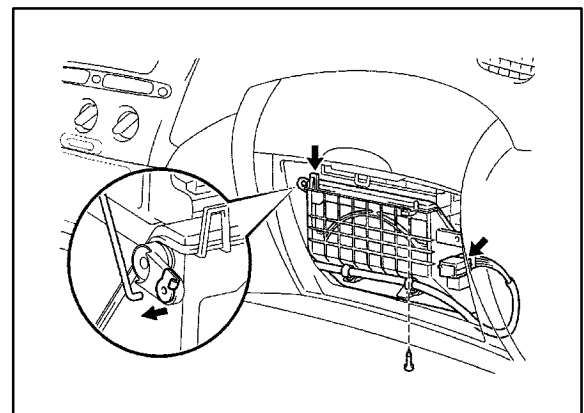

**Repair
Procedure:
Replacement**
(Continued)

4. **Remove Blower Resistor.**
 - A. Disconnect the connector.
 - B. Remove the 2 screws and blower resistor.

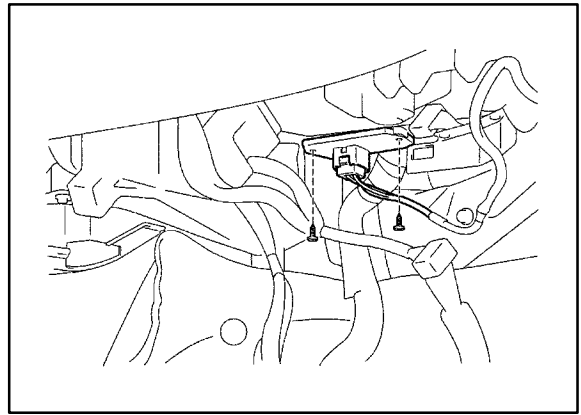

5. **Remove Blower Motor.**
 - A. Disconnect the connector.
 - B. Remove the 3 screws and blower motor.

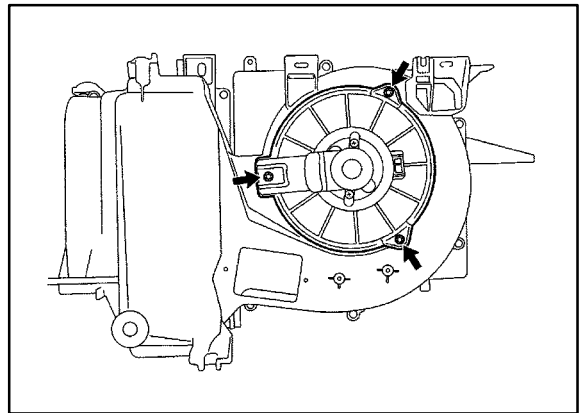

6. **Install New Blower Motor.**
7. **Install New Blower Resistor.**
8. **Cold Spec Heater Models Only:
Install Air Duct (Motor Cover).**
9. **Install Engine ECM (PCM).**
10. **Install Cabin Air Filter.**

NOTE:
The vehicle may not have had the cabin air filter. The addition of the filter is part of this repair procedure.

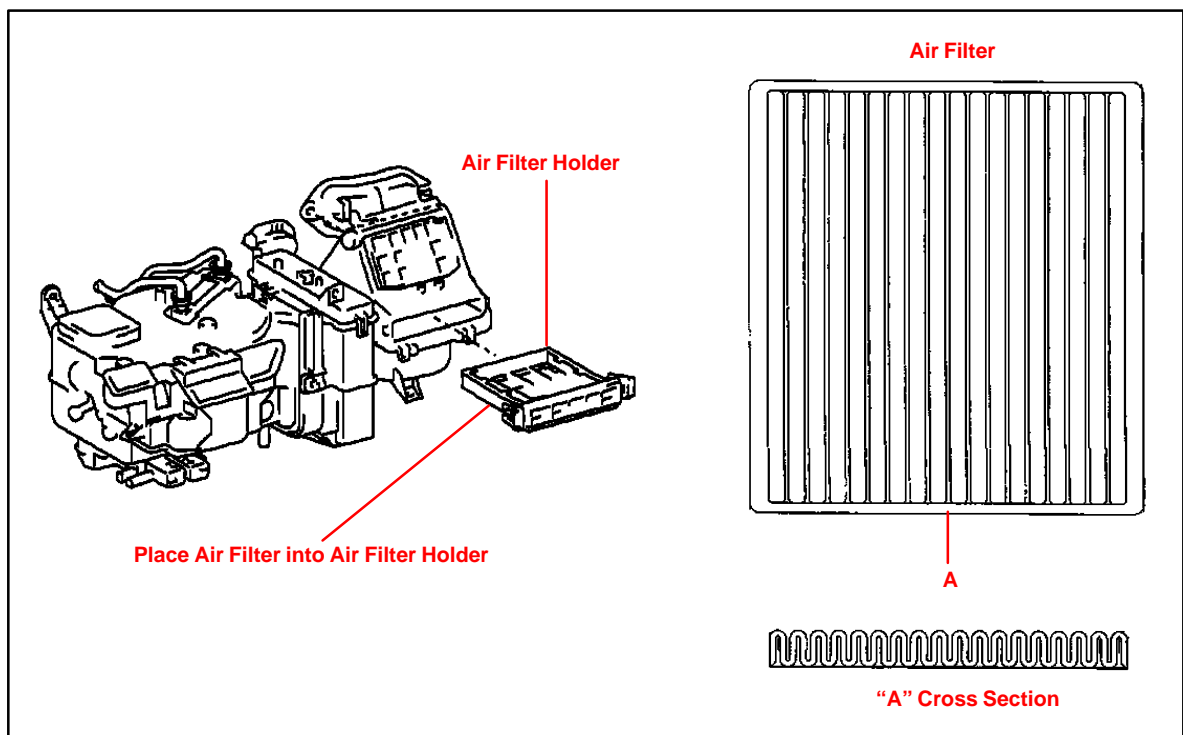

**Repair
Procedure:
Replacement
(Continued)**

- 11. Attach A/C Filter Label.**
Adhere the A/C Filter Label to the backside of the glove compartment door.
- 12. Install Glove Compartment Door.**
- 13. Verify the Operation of the Blower Motor at all Speeds.**

